



**VacuPrep™**  
VACUUM IMPREGNATION SYSTEMS

*DURABLE AND RELIABLE SYSTEMS  
FOR EPOXY ENCAPSULATION*

Quality Products for Metallographic Sample Preparation & Analysis



175-30000 - VacuPrep™



175-30050 - VacuPrep™ with Turntable

The **VacuPrep™** removes trapped air from uncured epoxy, filling open pores and cavities in samples to provide maximum bonding and support. This maintains sample integrity during abrasive preparation, reducing the chance of cracking or delamination. The turntable version allows for easy, accurate fill of multiple mounting cups under vacuum.

**Consumables are sold separately.**

Item	Description
175-30000	VacuPrep™
175-30050	VacuPrep™ with Turntable
Dims. 13" W x 18" D x 6" H (330 x 457 x 152 mm)	
Weight: 21 lb. (9.5 kg)	

### Features:

- Through-port for optional epoxy fill under vacuum
- Cup holder for mixed epoxy
- Pinch valve for efficient fill under vacuum
- Clear top to allow sample viewing during process
- Pull of up to 28 inHg vacuum
- Large 10" diameter x 4.5" deep (254 x 114 mm) chamber; capacity of up to thirty (30) 1.25" (32 mm) cups
- Quiet, pump-free operation
- 80 psi (5.5 bar) compressed air operation
- Dims. 13" W x 18" D x 6" H (330 x 457 x 152 mm)
- Weight: 21 lb. (9.5 kg)
- Two (2) year warranty
- Designed and manufactured by Allied in the USA 

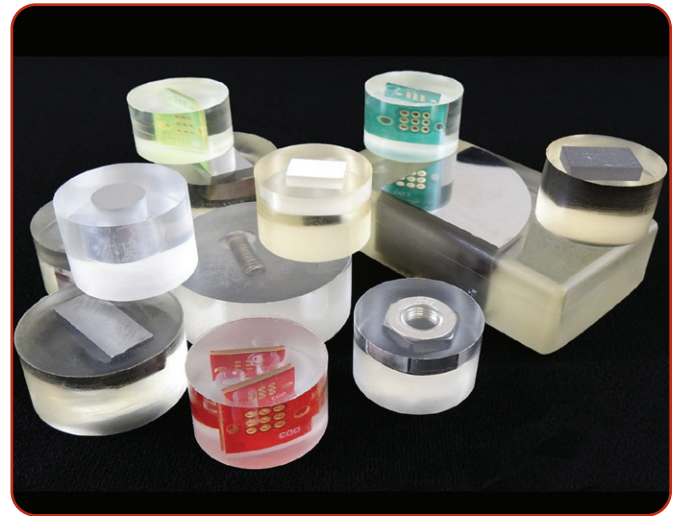

Accommodates all mount shapes & sizes



Turntable version allows continuous fill of mounting cups under vacuum



Simple, quiet compressed air operation



Clear top to allow sample viewing during process



Large 10" (254 mm) diameter chamber  
(turntable version shown with guide marks for mounting cups)



Easy access to directly pour epoxy into mounting cups



Through-port for optional epoxy fill under vacuum

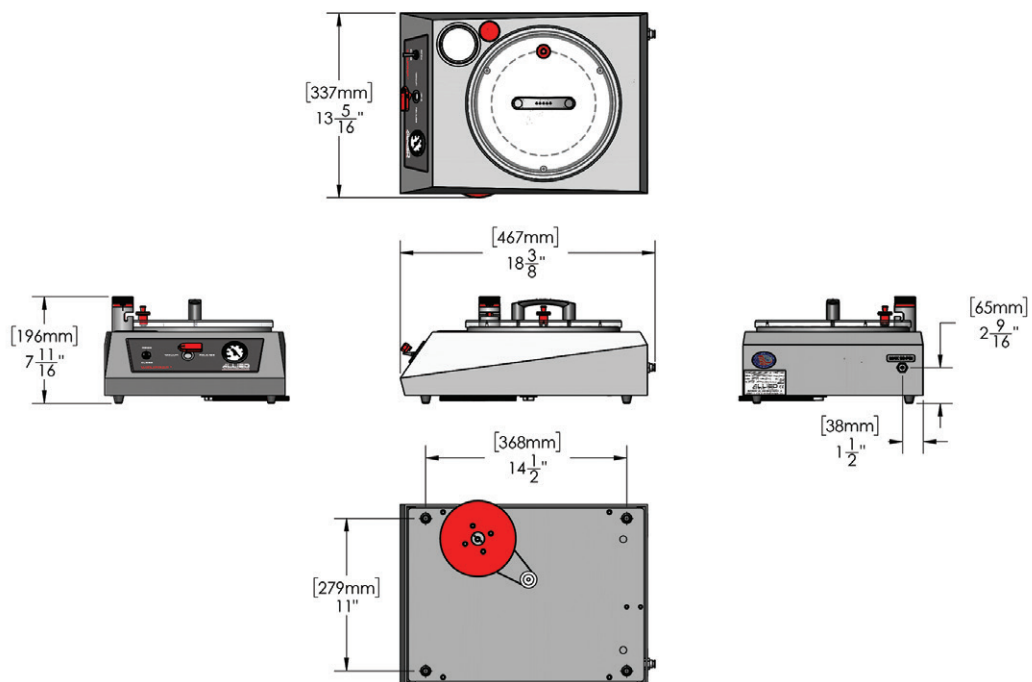

# Global Distribution of the World's Finest Products



Brochure #: VP-2022

Equipment is subject to change due to innovations/improvements at any time.



Designed and Manufactured by  
Allied High Tech Products, Inc.  
in the USA

**ALLIED**  
HIGH TECH PRODUCTS, INC.

2376 E. Pacifica Place, Rancho Dominguez, CA 90220  
310.635.2466 Worldwide / 800.675.1118 U.S. & Canada  
Visit us online! [AlliedHighTech.com](http://AlliedHighTech.com)